

KLIMA-FLEX COMPACT LATCH HINGE



The patented Klima-flex Compact Latch Hinge is specifically for insulated and pressurized doors. The hinge can be adjusted 3 mm in all three directions, it creates 3 mm compression and allows you to open the door 180° in either direction, or to remove the door completely.

A unique feature is that the compression can be adjusted an additional 1,5 or 3,0 mm. The safe two-stage opening process allows the cabinet to depressurize before it is fully opened.

Meets the requirements for sealing level L1 according to DIN EN 1886.



MATERIAL

- Adjustable off-set device:** Glass fibre reinforced Polyamide (PA6GF30)
- Door part:** Glass fibre reinforced polyamide (PA6GF30)
- Frame part:** Glass fibre reinforced Polyamide (PA6GF30)
- Handle:** Glass fibre reinforced polyamide (PA6GF30)
- Mounting bracket:** Glass fibre reinforced Polyamide (PA6GF30)
- Spring:** Spring steel EN 1.4310

RELATED PRODUCTS

Keys: 2-372, 2-370
Use the Index Code at industrilas.com

TESTS & STANDARDS

Standards: VDI 6022

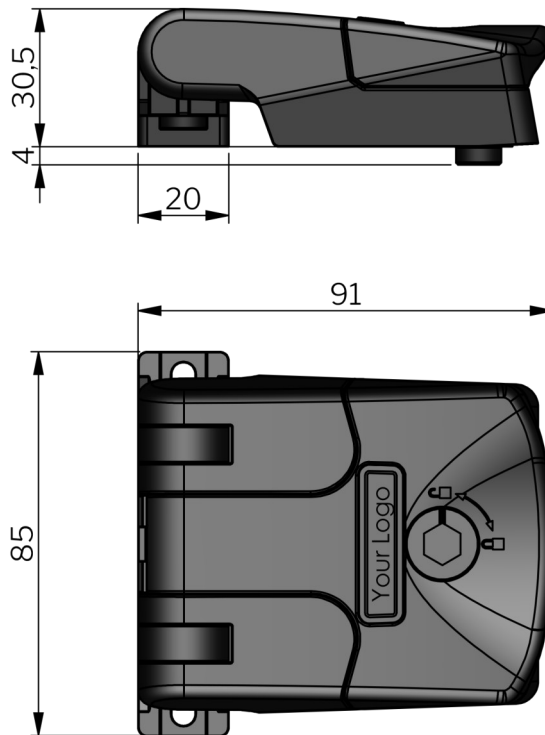

P/N	Description
2651-420034	With safety catch
2651-430034	Without safety catch

